

电动机 ELECTRIC MOTOR

200W

● 直角减速机 Right angle gearbox

型号 Model number	电机型号 Motor type	减速器型号 Type of reducer	减速比 Deceleration ratio
Z5BLD200-220GS-30S/20H□SF	Z5BLD200-220GS-30S	20H□SF	7.5 ~ 50

SF系列整机容许力矩 Machine allowable torque

● 直角减速机 Right angle gearbox

单位Unit: N·m

输出功率 Output power	电机轴转速 Motor speed	减速比 Reduction ratio				
		7.5	10	20	30	50
200W	80 ~ 2000RPM	3.8	5.0	10.2	14.5	24.3
	3000RPM	2.9	3.8	7.60	11.0	18.3

注Note：表格中 (灰底部分) 表示旋转方向与电机转向一致。The (gray) in the table indicates that the rotation direction is consistent with the motor. (不同转速及速比下的力矩为ZD标准驱动器下测试所得。The torque under different speed and speed ratio is obtained under the ZD standard)

外观尺寸图 Dimensional drawing

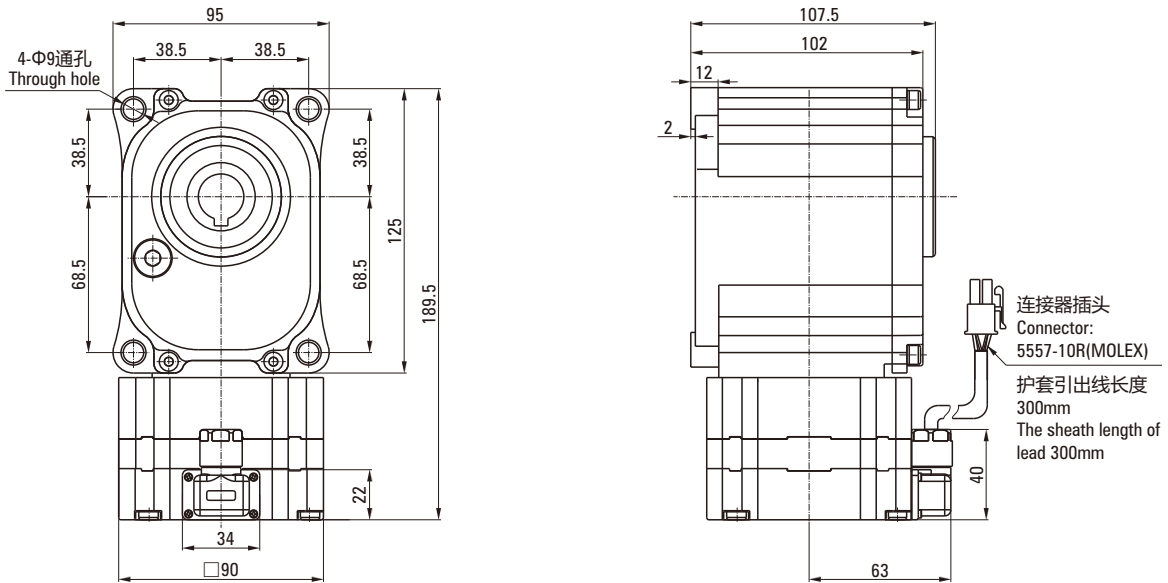

● 输出轴内孔结构 The output shaft hole structure

