

AC & DC
RIGHT
ANGLE GEAR MOTOR

003-095

ZD LEADER

AC GEAR MOTOR
交流减速电动机

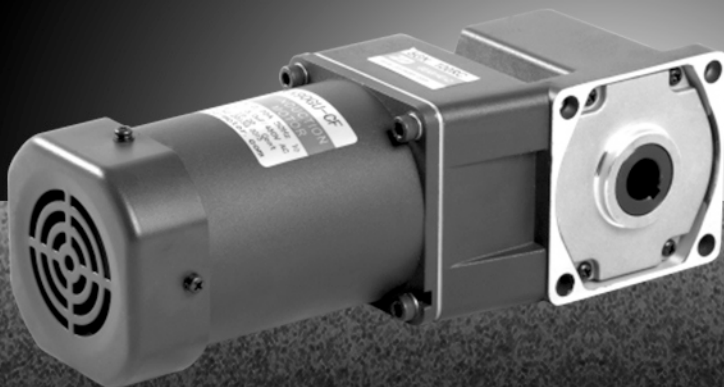

安全注意事项 SAFETY CAUTIONS

<p>总体 General</p>	<p>请不要在齿轮箱及电机铭牌或产品目录的规格以外使用，以免触电，受伤及损坏装置等。 Please don't use motor out of the range which is clarified in of nameplate of gear box and motor and the specification of product catalogue, avoiding getting an electric shock, hurting or damaging the device.</p> <p>请不要把手指或物品进入齿轮或电机开口部分，以免触电、受伤、发生火灾及损坏装置等。 Please do not put your fingers into the opening part of gear of motor, in order to prevent getting an electric shock, hurting catching a fire or damaging device etc.</p> <p>请不要使用带伤的齿轮箱或电机，以免有可能受伤，发生火灾等。 Please do not use the injured gear head or motor, in order to prevent hurting, catching a fire etc.</p> <p>请不要拆下铭牌。 Please do not put off the nameplate.</p> <p>若客户对产品私自进行改造的，不属于保修范围，本公司不承担任何责任。 If the products are reformed by the customers personally, it no belongs to the guarantee scope, and our company doesn't undertake any responsibility.</p>
<p>搬动/Moving</p>	<p>搬动时，若发生脱落或倾倒，是很危险的，请充分注意。 When you move it, if it shed off or tit to one side, it is very dangerous, please pay more attention.</p>
<p>安装 Assembly</p>	<p>请绝对不要在齿轮箱和电机周围放置可燃物，以免发生火灾。 Please never put the flammable thing near and motor, for fear of a fire.</p> <p>请不要在电机周围放置物品，影响电机通风、冷却，甚至因异常多热而烫伤或发生火灾。 Please do not put the things around motor, otherwise it can effect ventilation and cooling, even burning or catching a fire because of too hot.</p> <p>裸手请不要触碰齿轮及电机轴端部、齿轮部的键槽，以免受伤。 Please do not touch the gear, the motor shaft and the key slot of the gear with naked hand, or you may be hurt.</p> <p>在食品机械等可能发生漏油的装置中，请在安装部分另加一个能盛油的油杯，防止万一漏油对产品有不良的影响。 The device may creating the smoke, such as food machine, please add an oil cup assembly part, to prevent leaking oil which may have a bad effect.</p>
<p>对主机械的连接 Assemble to the main machine</p>	<p>在旋转部分，请设安全罩等，防止受伤。 Please set a safe cover above the revolving part, to prevent being hurt.</p> <p>在与对方机械连接前，请确认旋转方向。若旋转方向不正确，有可能受伤或破坏装置。 Before linking to the other machine, please confirm the revolving direction is not right, it may hurt the gear motor or destroy the device.</p>
<p>配线/Wiring</p>	<p>在测试绝缘电阻时，请不要接触端子，以免触电危险。 Please don't get in touch with terminal, when you measure insure insulated resistance, preventing danger of getting an electric shock.</p>
<p>运转 Operation</p>	<p>请按照接线图或使用说明书实施与电源的连接，以免触电或发生火灾。（无端子箱的，请确实加强连接部分的绝缘） Please link with the electric source according to wire diagram and usage manual, in order to prevent getting an electric shock or catching a fire. (no terminal box, please strengthen the insulation of the connection part surely)</p> <p>对电源电缆和电机引线，请不要过分弯曲、拉伸、夹紧，以免触电危险。 Referring to the electrical source cable and the motor wire, please do not bend, stretch, and clip tightly excessively, in order to prevent getting an electric shock.</p> <p>接地端子应牢固接地，以免触电危险。务必使用符合铭牌要求的电源，以免烧毁电机、发生火灾。 The terminal box connecting to the ground must be firm, in order to prevent getting an electric shock. Please adopt the electrical source according to the nameplate, to avoid burning the motor and catching a fire.</p>
<p>日常检查保养 The daily check and maintain</p>	<p>在运转中，绝对不要接近或接触旋转物体（轴等）。有卷入受伤时，请马上切断电源开关，及时处理。 When operating, do not get close to or touch the revolving parts (shaft). If something or somebody engulfs or hurts, Please turn off the electrical power switch right and handle at once.</p> <p>停电时，请务必切断电源开关，防止来电后伤人或破坏装置。 Please turn off the electrical source switch when electricity stops, in order to prevent hurting the person and damaging the device.</p> <p>请注意：带有热保护的电机，当电机温度异常时会自动切断电源，当电机温度下降到一定值时，电机会自动恢复工作。 (注：电机在没有烧坏的情况下，会自动复原) Please note, motor with the thermal protector, when temperature of the motor is unusual, it will turn off the electrical source automatically, when the temperature of the motor fall down to a fixed data, the motor can work automatically. (Note: when the motor is not burned-not, the motor can work automatically)</p> <p>在平常时，保持电机在正常的工作环境工作运转。（特殊型号除外） In daily, you should keep the motor operating in the normal work environment. (Except the special model)</p> <p>检查时，请绝对不要接触旋转物体（轴等）。有可能被卷入、受伤。 While checking, please do not get close to or touch the revolving parts (shaft). Something or somebody may engulf of hurt.</p>
<p>接受货物时检查 Receiving confirm</p>	<p>请确认现货是否和订货一样。选择错误的产品，有可能导致电机受损或破坏装置等。 Please confirm if it is the right one with the order when receiving Choosing wrong probably leads to damage of motor of damage the device and etc.</p>

型号的阅读方法 PRODUCT NUMBER CODE

电动机 Motor

5 I K 40 R GU - C T
① ② ③ ④ ⑤ ⑥ ⑦ ⑧

①	电动机的尺寸 Motor frame size	4: 80mm 5: 90mm 6: 104mm
②	类型名称 Motor type	I : 感应电动机 Induction motor R : 可逆电动机 Reversible motor
③	系列名称 Series	K : K系列 K series
④	输出功率 Output power (W)	(例 Example) 40 : 40W
⑤	R : 表示带调速电动机 ; 无 : 表示未带 The suffix "-R" after the output power means speed adjustable motor	
⑥	转轴形状 Motor shaft type	GN : GN型齿轮轴 GN type : Pinion shaft GU : GU型齿轮轴 GU Type : Pinion shaft
⑦	电源电压·极数 Voltage-Poles	A : 单相Single-phase 110V50/60Hz 4P E : 单相Single-phase 110V/120V60Hz 4P S3 : 三相Three-phase 380/400/415V50/60Hz 4P B : 单相Single-phase 110V50Hz 2P H : 单相Single-phase 220/230V60Hz 4P T : 三相Three-phase 200/220/230V50/60Hz 2P C : 单相Single-phase 220/230V50Hz 4P S : 三相Three-phase 200/220/230V50/60Hz 4P T3 : 三相Three-phase 380/400/415V50/60Hz 2P D : 单相Single-phase 220V50Hz 2P
⑧	T : 带端子箱型 Terminal box type F : 带风扇 W/Fan M : 无励磁动作型电磁制动电动机 Power off activated type electromagnetic brake motor	FF : 带强制风扇 W/Forced fan

减速器型号说明 Description Of Reducer Model

5 GU 50 RH
① ② ③ ④

①	减速器安装尺寸 Gearhead frame size	4: 80mm 5: 90mm 6: 104mm
②	类型 Type of pinion	GN : GN型齿轮轴 GN type gear GU : GU型齿轮轴 GU type gear
③	减速比 Gear ratio	(例e.g) 50 : 减速比 Gear ratio of 1 : 50 10x仅限减速器1 : 10的中间减速比 10x denotes the decimal gearhead of ratio 1 : 10 RH : 蜗轮蜗杆空心轴输出 Hollow worm shaft RA : 蜗轮蜗杆实心轴输出 Worn output shaft RC : 弧锥齿空心轴输出 Spiral bevel hollow shaft RT : 弧锥齿实心轴输出 Spiral bevel output shaft
④	输出种类 Type of output shaft	

直角系列 Right Angle Series

引线款 Lead Style

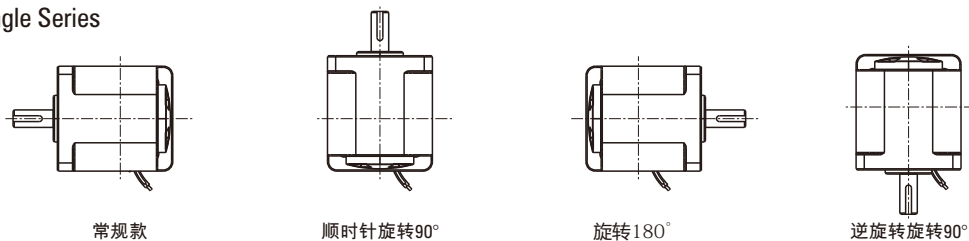

接线盒款 Junction Box

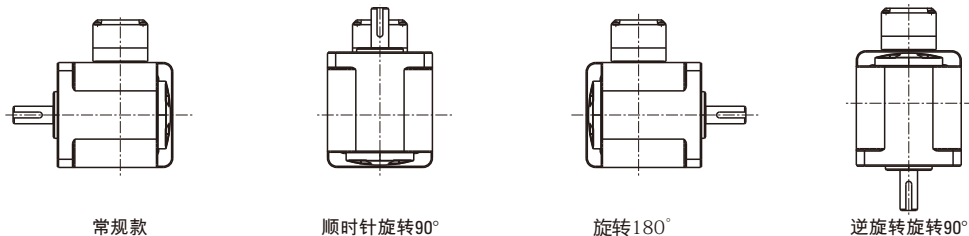

电动机的一般规格 GENERAL SPECIFICATIONS OF MOTORS

25W~200W型

项目 Item	规格 Specifications
绝缘电阻 Insulation Resistance	于常温·常湿下的电动机额定运行后,以DC 500V电阻表测量线圈·外壳间时,测量值为100MΩ以上 In the circumstance of normal temperature and humidity, the resistance can be up to 100MΩ, measured DC 500V insulation resistance measurer between the motor wiring and motor shell while the motor is working
绝缘耐压 Insulation Voltage	于常温·常湿下电动机额定运行后,在线圈·外壳间施加一分钟50Hz或60Hz、1.5kV(三相400V为2kV)的电压,亦无异常 In the circumstance of normal temperature and humidity, there will be no problem supplying the power of 1.5kV (three phase 400V: 2kV) at 50/60Hz between the metal wiring and motor shell for 1 minute while the motor is working
温度上升 Temperature Rise	在装上减速机或同等散热板※并于常温·常湿下进行额定运行时,以电阻法测定其线圈温度上升值为80℃以下(三相型为70℃以下) The temperature rise of winding are 80℃ or less measured by the resistance change method after rated motor operation under normal ambient temperature and humidity, with connecting a gearhead or equivalent heat radiation plate ※
绝缘等级 Insulation Class	UL/CSA规格: A种(105℃)、EN规格: B种(130℃) UL/CSA Standards: Class A (105℃) EN Standards: Class B (130℃)
过热保护装置 Overheat Protection	内藏热保护装置(自动复位型) B种(开放: 120℃±5℃、75℃±15℃) F种(开放: 145℃±5℃、100℃±15℃) Thermal protector inside (Automatic return) Class B (Opening: 120℃±5℃、75℃±15℃) Class F (Opening: 145℃±5℃、100℃±15℃)
使用环境温度 Ambient Temperature	单相100V、三相200V: -10~+50℃(无结冰)、其他电压: -10~+40℃(无结冰) Single-phase 100V、Three-phase 200V: -10~+50℃ (Non freezing)、Others: -10~+40℃ (Non freezing)
使用环境湿度 Ambient Humidity	85%以下(无结露) ≤85% (Non condensing)
保护等级 Protection Class	导线型 Lead wire type: IP20 带端子箱型 Terminal box type: 单相 Single-phase 100V50/60Hz、110/120V60Hz、220/230V50Hz、220/230V60Hz 25W-180W Type: IP54 (不包括圆轴安装面 Excluding the installation surface of the round shaft type) 三相 Three-phase 200/220/230V50/60Hz、380/400/415V50/60Hz 25W-180W Type: IP54 (不包括圆轴安装面 Excluding the installation surface of the round shaft type)

散热板尺寸(材质: 铝) Heat Radiation Plate (Material: Aluminum)

电动类型 Motor Type	尺寸 Size	厚度 Thickness (mm)
25W	135X135	5
40W、60W type	165X165	
60W、90W、120W type	200X200	
120W、140W、200W type	230X230	

电动机的特性 MOTOR FEATURES

■ 感应电动机的特性 Induction Motor Features

- 1、一般来说，微型感应电动机所指的是感应运转型感应电动机。这种电动机不只在启动时，在运转当中也使用电磁线圈和电容器。虽然启动转矩不是很大，但其结构简单，信赖度高，效率也比较高，可连续运转。
Generally, Micro induction motor refers to the motor rotated by the induction. Induction motor relies on capacitor and electromagnetism when starting and rotating. Though its starting torque is not very high, it has a simple structure, high efficiency and can rotate continue.
- 2、单相电动机运转时，产生与运转方向逆方向的转矩，因此不可能在短时间内改变方向。请在电动机完全停止以后，再转换其运转方向。
The single-phase motor have a reverse direction with the rotating's when operated. Pls change the direction of single-phase motor rotation only after bring the motor to a stop.
- 3、三相电动机以三相电源驱动感应电动机，其效率很高，启动力矩也比较大，信赖度高。
Three-phase motor relies on three-phase supply, it has a high efficiency and can get a high starting torque.

■ 可逆电动机的特性 Reversible Motor Features

- 1、可逆电动机，在电动机后部设有简易制动器，是适用于短时间内频繁正反转用途的电机。简易制动器的构造，如图1所示，带弹簧压力的制动柱作用在转动的制动盘上并保持连续压力。可逆电动机的简易制动器如下作用：
Reversible motor has a friction brake at the back of the motor body, which is designed for applications where reversal of direction is frequently required. For the friction brake, pls check draw 1. The damp with spring impacts the rotating brake disk and supplies with continuous press. The functions of the friction brake are as following:

- ① 加摩擦负荷，提高瞬间可逆特性。
With friction load, increasing the instant reversal.
- ② 缩小超程。
Shorten over-run.
- ③ 具有某种程度的保持力矩。（额定力矩10%左右）
Keep the torque in some way. (About 10% of the rated torque)

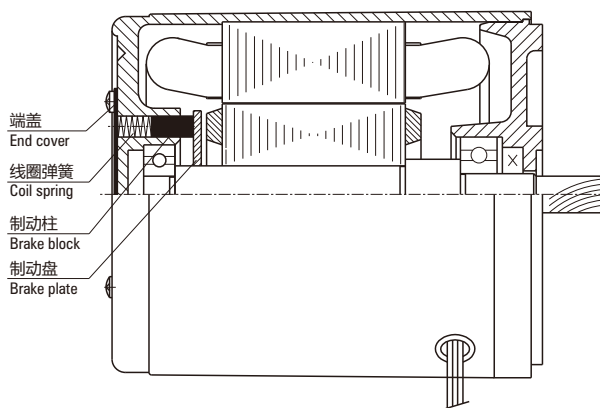

如图 /Fig.1

- 2、简易制动器的保持力矩及超程表示在表1，但随着转动时间的长短或温度高低，也会有变化，仅供参考。且初期使用，其保持力矩比表1的值低的情况也会发生，请注意。
The keeping torque or more of the friction brake and over-run are listed in the table 1. It is only for reference. As it will change according to the rotating period as well as the temperature. Pls also note that the torque may be a little lower than the one listed in the table when being operated initially.
- 3、可逆电动机和感应电动机相同，都是电容启动单相电机，转矩力矩特性与感应电机特性相同。但是，为了提高瞬间可逆特性，如图2所示，设计为加大启动力矩。受此影响，加大了输入的损耗，温升比感应电动机高，因此，时间定额为30分钟。特性表中的额定力矩，启动力矩，电流特性等是在电机上装上有制动柱状态下的特性值。
The reversible motor, like induction motor, is started by the capacitor and has a same torque characteristic with the induction motor. But the reversible Motor is designed with a higher starting torque to increase the instant reversal features. Pls check drawing 2.

■ 表1.保持力矩和超程 Table 1. Keep Torque And Over-run

相数 Phase	尺寸 Size	输出功率 Output	电机型号 Motor Model	保持力矩 Keep Torque		超程 Over-run
	mm			W	N.cm	Kgf.cm
单相 Sing-Phase	80	25	4RK25	1.5	0.14	5
	90	40	5RK40	4.0	0.40	6
		60	5RK60			
		90	5RK90			
120	5RK120					

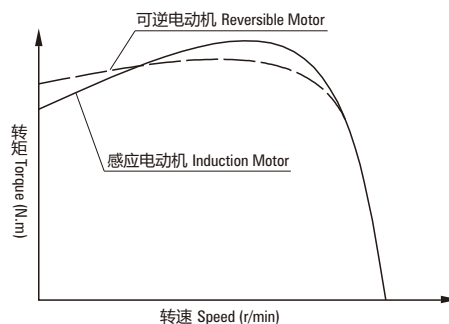

如图 /Fig.2

■ 无励磁动作型电磁制动电动机特性 Power Off Activated Type Electromagnetic Brake Motor Features

1、构造及运行原理 Structure and operation principle

图3是带电磁制动的电机的构造图。本公司生产的电磁制动电动机是无励磁动作型，在线圈上施加电压，则立即吸引被弹簧压着的可动衔铁，在可动衔铁和制动衬套之间产生间隙，使电机处于运转状态。一旦线圈电压被切断，在弹簧力的作用下，可动衔铁压向制动衬套，产生制动力，电机停止。

Table 3 is the structure for the electromagnetic brake motor. We produce the power off activated type. Exerting the voltage on the winding, it will magnetize the armature pressed by the spring. The motor will be in a stage of rotating, when there is a backlash between the armature and brake rim. Once the winding voltage is cut down, under the influence of spring, the armature press the brake rim, which will create a brake force. Then the motor gets to a stop.

2、电磁制动器的特点 The characteristics of the electromagnetic brake

该制动器是交流无励磁动作型电磁制动器，与电机直接连接。在切断电源的同时，即瞬间停止，保持负荷。保持力矩0.05~2.0N.m（参照表2）。由于是电源切断时的保持力动作型，故最适合于作为无意间切断电源时的安全制动器使用。电磁可以进行频繁的瞬间正反转。简单的切换，1分钟内可停止6次。但是时间必须确保3秒以上。

It is an AC power off activated type electromagnetic brake which is connected directly with the motor. It will get to a blink stop and keep load when the supply is power off. It will keep the torque between 0.05~2.0Nm. It is especially suitable for the safety brake in the circumstance of unconsciously power off. The electromagnetic can change its direction frequently. It can be stopped 6 times in a minute. But be sure that it lasts for 3 seconds or more.

电机和制动器可以使用同一个电源。制动器内设置整流回路，可和电机使用同一个交流电源。

After we set a commutating loop in the brake, it can share the power supply with the motor.

※这个数值是标准的，根据使用条件的不同，以这个频度连续使用不能进行制动器操作的情况也有，实际使用时，必须在电机表面温度为90度以下的条件下使用。

※ The value is standard. It will be change in different condition. When actually used, be sure to make the surface temperature of the motor less than 90°C.

3、起动时间，制动时间的特性 The features for the starting time and brake time

电磁制动电机的起动时间是电机自身的起动时间加上电磁制动器的释放时间，制动时间是从电源切断开始至电机完全停止的时间。电磁制动电机的超程、起动时间、制动时间应用场合而不同。

The starting time means the time for the motor's starting time plus the electromagnetic brake release time. The brake time means the time from power cut off to the time of motor completely stop. The over-run, starting time and brake time will be different according to the different applications.

■ 表2.电磁制动部分（无励磁动作型） Electromagnetic Brake (Power Off Activated Type)

相数 Phase	基座 尺寸 Size MM	输出 功率 Output W	电压 Voltage V	频率 Frequency Hz	电流 Current A	输入 功率 Input W	保持力矩 Keep Torque		超程 Over-run
							N.cm	Kgf.cm	圈数 Cycles
1Phase	80	25	110 120 220 230	50/60	0.091	8.20	0.50	50	3.5
		40							
	90	60			0.111	10.0	1.00	100	
		90							
		120							
		120							
	100	140			0.144	13.0	2.00	200	
		200							
3Phase	80	25	200~230 380~415	50/60	0.091	8.20	0.50	50	3.5
		40							
	90	60			0.046	8.20	0.50	50	
		90							
		120							
		120							
	100	140			0.056	10.0	1.00	100	
		200							
	100	200			0.144	13.0	2.00	200	
		200							

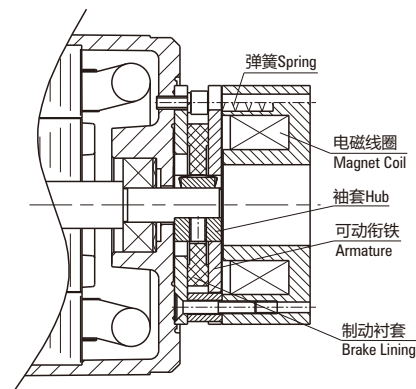

如图 /Fig.3

■ 调速电机特性 The Features Of The Speed Control Motor

1、控制器和电机组合的单元产品，由于电机和控制品只需一次连接，故不需要单独接线。速度调节由安装在外部的电位器便可简单进行。在控制器上安装了速度控制器回路、电机用的电容，速度设定器等。其中单元式速度控制器无瞬间停止功能。

It is a unit of the controller and motor. It only needs to connect one time. The speed can be easily adjusted by the potentiometer. The controller is fixed with speed-control loop, capacitor, speed enactment and etc. There is no function of instant stop in the unit.

2、用控制器的速度调节器进行速度调节。可以在50Hz为90~1400r/min，60Hz为90~1700r/min范围内，调节电机的速度。

The controller can make the speed variable between 90~1400r/min at 50Hz and 90~1700r/min at 60Hz.

3、电机不允许长时间在低转速下运行，以免电机过热。

Please don't run motor at low speed for long time avoiding overheat.

感应电动机 INDUCTION MOTORS

■ 25W □ 80mm



规格 Specs 连续额定 Continuous Rating

型号Model · 类型 Type 上段:齿轮轴 Upper:Pinion Shaft 下段()内:圆轴 Below:Round Shaft		输出功率 Output power W	电压 Voltage V	频率 Frequency Hz	电流 Current A	启动转矩 Starting Torque mN.m	额定转矩 Rated Torque mN.m	额定转速 Rated Speed r/min	电容器容量 Capacitor μF
导线型 Lead Wire Type 外形图Dimensions①	带端子箱型 Terminal Box Type 外形图Dimensions②								
4IK25GN-A	4IK25GN-AT	25	1ph 100	50	0.500	120	200	1250	8.0
				60	0.550		165	1550	
4IK25GN-E	4IK25GN-ET	25	1ph 110	60	0.450	120	165	1550	7.0
			1ph 120		0.500				
4IK25GN-C	4IK25GN-CT	25	1ph 220	50	0.250	120	200	1250	1.8
			1ph 230		0.230				
4IK25GN-H	4IK25GN-HT	25	1ph 220	60	0.230	120	165	1550	1.8
			1ph 230						
4IK25GN-S	4IK25GN-ST	25	3ph 220	50	0.185	350	200	1250	-
				60	0.170	250	165	1550	
4IK25GN-S3	4IK25GN-S3T	25	3ph 380	50	0.107	350	200	1250	-
				60	0.098	250	165	1550	

- 各种安全规格以电动机铭牌上的型号名取得认证。
When the motor is approved under various safety standards, the model name on the nameplate is the approved model name.
- 注：“-A”型号中电压为110V时，配置电容器容量以实际铭牌为准。
Note:“-A” it means the voltage 110V, the assembly capacitor vaule it is according the labe.

装有减速器时的容许转矩 Gear Motor-Torque Table

- 减速器-中间减速器另售。● 电动机型号的□中为表示带端子箱型的记号(T)。
Gearhead and mid-gearbox can be sold separately. Enter the code that represents the terminal box type (T) in the box (□) within the model name.
- 减速器型号的□中为减速比的数值。□色表示与电动机同一方向运转，其他则为相反方向。
Enter the gear ratio in the box (□) within the model name.
The colored background □ indicates the same rotating direction of the motor while the rotating direction of others are opposite.
- 转速是以电动机的同步转速 (50Hz:1500r/min、60Hz:1800r/min) 为基准除以减速比而算出来的数值。实际转速将随负载大小变化而比所示数值减少2%~20%左右。
The speed is calculated by diving the motor's synchronous speed (50Hz:1500r/min、60Hz:1800r/min) by the gear ratio. The actual speed is 2%~20% less than the displayed value, depending on the size of the load.
- 希望以大于下表的减速比进行进一步减速时，可在电动机与减速器之间安装减速比为10的中间减速器。这时的容许转矩为8N·m。
To reduce the speed beyond the gear ratio in the table, attach a mid-gearbox (gear ratio:10) between the gearhead and motor. In that case, the permissible torque is 8N·m.

弧锥直角 SPIRAL BEVEL RIGHT ANGLE

容许力矩单位 Allowance Torque Unit: 上段 Upside (N.m) / 下段 Belowside (kgf.cm)

机型Type		减速比Gear Ratio	7.5	9	12.5	15	18	25	30	36	50	60	75	90	100	120	150	180		
电动机/减速器 Motor/Gearhead	转速Speed r/min	50Hz	200	166	120	100	83	60	50	42	30	25	20	16	15	12	10	8		
		60Hz	240	200	144	120	100	72	60	50	36	30	24	20	18	15	12	10		
4K25GN-A□ 4K25GN-E□ 4K25GN-C□ 4K25GN-H□ 4K25GN-S□ 4K25GN-S3□	4GN□RC 4GN□RT	容许力矩 Allowance Torque	50Hz	0.99	1.18	1.64	1.97	2.37	3.29	3.95	4.73	6.58	7.10	8.00	8.00	8.00	8.00	8.00	8.00	
			60Hz	0.80	0.95	1.33	1.59	1.91	2.65	3.18	3.82	5.30	5.73	7.16	8.00	8.00	8.00	8.00	8.00	
			50Hz	10.1	12.1	16.8	20.1	24.2	33.5	40.3	48.3	67.1	72.5	80.0	80.0	80.0	80.0	80.0	80.0	80.0
			60Hz	8.12	9.74	13.5	16.2	19.5	27.1	32.5	39.0	54.1	58.4	73.0	80.0	80.0	80.0	80.0	80.0	80.0
			50Hz	0.99	1.18	1.64	1.97	2.37	3.29	3.95	4.73	6.58	7.10	8.00	8.00	8.00	8.00	8.00	8.00	8.00
			60Hz	0.80	0.95	1.33	1.59	1.91	2.65	3.18	3.82	5.30	5.73	7.16	8.00	8.00	8.00	8.00	8.00	8.00

电机尺寸图 Motor Size Chart

4K25GN-A□/4GN□RC 4K25GN-E□/4GN□RC	4K25GN-C□/4GN□RC 4K25GN-H□/4GN□RC	4K25GN-S□/4GN□RC 4K25GN-S3□/4GN□RC
--------------------------------------	--------------------------------------	---------------------------------------

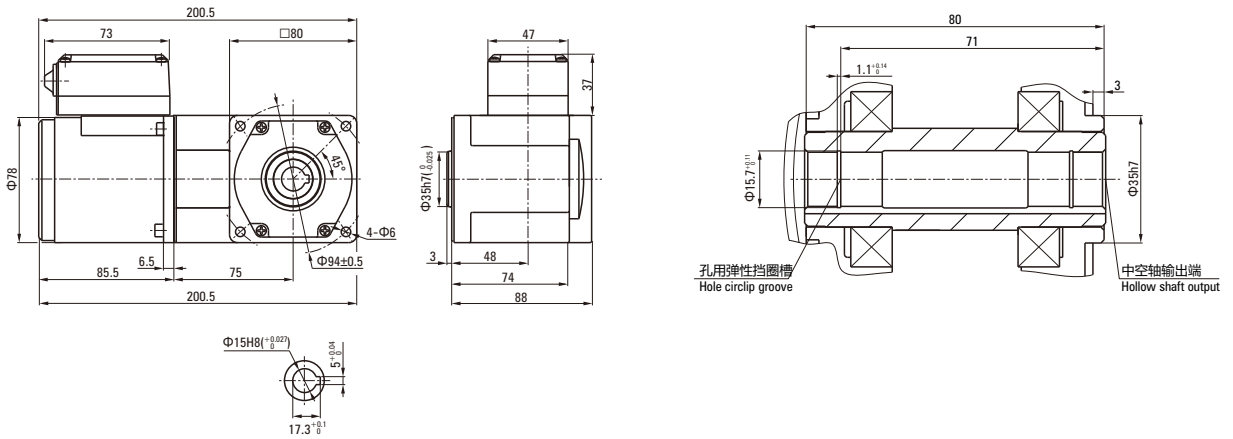

4K25GN-A□/4GN□RT 4K25GN-E□/4GN□RT	4K25GN-C□/4GN□RT 4K25GN-H□/4GN□RT	4K25GN-S□/4GN□RT 4K25GN-S3□/4GN□RT
--------------------------------------	--------------------------------------	---------------------------------------

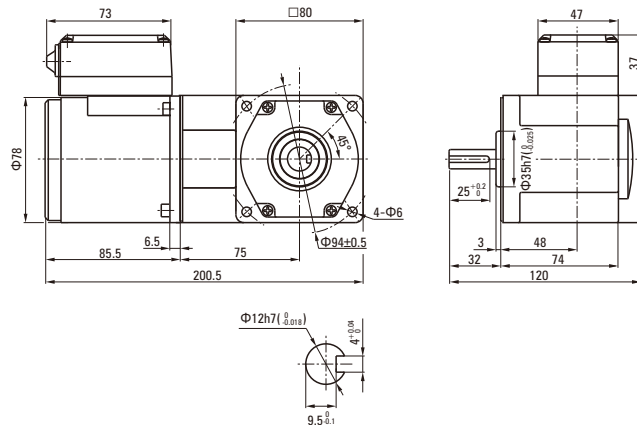

感应电动机 INDUCTION MOTORS

■ 40W □ 90mm



规格 Specs 连续额定 Continuous Rating

型号Model · 类型 Type 上段:齿轮轴 Upper:Pinion Shaft 下段()内:圆轴 Below:Round Shaft		输出功率 Output power W	电压 Voltage V	频率 Frequency Hz	电流 Current A	启动转矩 Starting Torque mN.m	额定转矩 Rated Torque mN.m	额定转速 Rated Speed r/min	电容器容量 Capacitor μF
导线型 Lead Wire Type 外形图Dimensions①	带端子箱型 Terminal Box Type 外形图Dimensions②								
5IK40GU-A	5IK40GU-AT	40	1ph 100	50	0.65	220	315	1250	12
				60	0.70		260	1550	
5IK40GU-E	5IK40GU-ET	40	1ph 110	60	0.55	200	260	1550	8.0
			1ph 120		0.60				
5IK40GU-C	5IK40GU-CT	40	1ph 220	50	0.35	220	315	1250	2.5
			1ph 230		0.40				
5IK40GU-H	5IK40GU-HT	40	1ph 220	60	0.35	200	260	1550	2.5
			1ph 230		0.40				
5IK40GU-S	5IK40GU-ST	40	3ph 220	50	0.30	800	315	1250	-
				60	0.25		250	1550	
5IK40GU-S3	5IK40GU-S3T	40	3ph 380	50	0.17	800	315	1250	-
				60	0.14		250	1550	

- 各种安全规格以电动机铭牌上的型号名取得认证。
When the motor is approved under various safety standards, the model name on the nameplate is the approved model name.
- 注：“-A”型号中电压为110V时，配置电容器容量以实际铭牌为准。
Note: "-A" it means the voltage 110V, the assembly capacitor vaule it is according the labe.

装有减速器时的容许转矩 Gear Motor-Torque Table

- 减速器-中间减速器另售。● 电动机型号的□中为表示带端子箱型的记号(T)。
Gearhead and mid-gearbox can be sold separately. Enter the code that represents the terminal box type (T) in the box (□) within the model name.
- 减速器型号的□中为减速比的数值。□色表示与电动机同一方向运转，其他则为相反方向。
Enter the gear ratio in the box (□) within the model name.
The colored background □ indicates the same rotating direction of the motor while the rotating direction of others are opposite.
- 转速是以电动机的同步转速 (50Hz:1500r/min、60Hz:1800r/min) 为基准除以减速比而算出来的数值。实际转速将随负载大小变化而比所示数值减少2%~20%左右。
The speed is calculated by diving the motor's synchronous speed (50Hz:1500r/min、60Hz:1800r/min) by the gear ratio. The actual speed is 2%~20% less than the displayed value, depending on the size of the load.
- 希望以大于下表的减速比进行进一步减速时，可在电动机与减速器之间安装减速比为10的中间减速器。这时的容许转矩为20N·m。
To reduce the speed beyond the gear ratio in the table, attach a mid-gearbox (gear ratio:10) between the gearhead and motor. In that case, the permissible torque is 20N·m.

弧锥直角 SPIRAL BEVEL RIGHT ANGLE

容许力矩单位 Allowance Torque Unit: 上段 Upside (N.m) / 下段 Belowside (kgf.cm)

机型Type		减速比Gear Ratio	7.5	9	12.5	15	18	25	30	36	50	60	75	90	100	120	150	180		
电动机/减速器 Motor/Gearhead	转速Speed r/min	50Hz	200	166	120	100	83	60	50	42	30	25	20	16	15	12	10	8		
		60Hz	240	200	144	120	100	72	60	50	36	30	24	20	18	15	12	10		
5IK40GU-A□ 5IK40GU-E□ 5IK40GU-C□ 5IK40GU-H□ 5IK40GU-S□ 5IK40GU-S3□	5GU□RC 5GU□RT	容许力矩 Allowance Torque	50Hz	1.58	1.89	2.63	3.16	3.79	5.26	6.31	6.80	9.50	11.4	14.2	17.0	18.9	20.0	20.0	20.0	
			60Hz	1.27	1.53	2.12	2.55	3.05	4.24	5.09	5.50	7.64	9.16	11.5	13.7	15.3	18.3	20.0	20.0	
				50Hz	16.1	19.3	26.8	32.2	38.6	53.7	64.4	70.0	97.0	116	145	174	193	200	200	200
				60Hz	13.0	15.6	21.6	26.0	31.2	43.3	51.9	56.1	77.9	93.5	117	140	156	187	200	200

电机尺寸图 Motor Size Chart

5IK40GU-A□/5GU□RC 5IK40GU-E□/5GU□RC	5IK40GU-C□/5GU□RC 5IK40GU-H□/5GU□RC	5IK40GU-S□/5GU□RC 5IK40GU-S3□/5GU□RC
----------------------------------------	----------------------------------------	-----------------------------------------

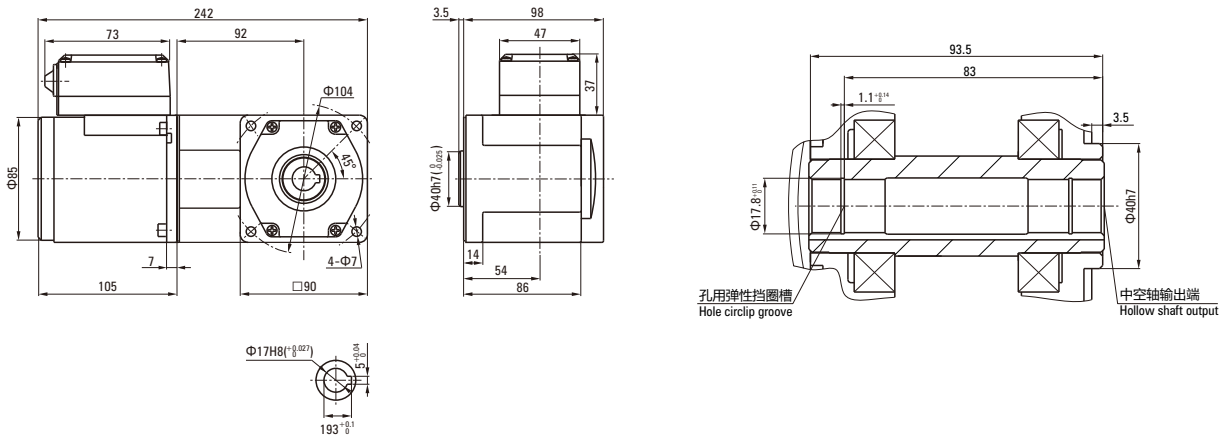

5IK40GU-A□/5GU□RT 5IK40GU-E□/5GU□RT	5IK40GU-C□/5GU□RT 5IK40GU-H□/5GU□RT	5IK40GU-S□/5GU□RT 5IK40GU-S3□/5GU□RT
----------------------------------------	----------------------------------------	-----------------------------------------

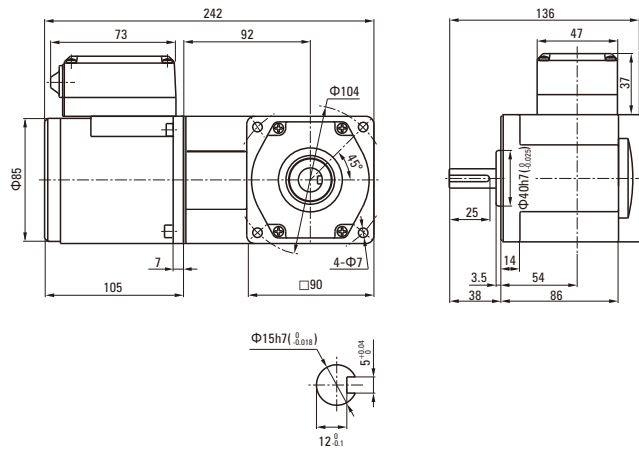

感应电动机 INDUCTION MOTORS

■ 60W □ 90mm



规格 Specs 连续额定 Continuous Rating

型号Model · 类型 Type 上段:齿轮轴 Upper:Pinion Shaft 下段()内:圆轴 Below:Round Shaft		输出功率 Output power W	电压 Voltage V	频率 Frequency Hz	电流 Current A	启动转矩 Starting Torque mN.m	额定转矩 Rated Torque mN.m	额定转速 Rated Speed r/min	电容器容量 Capacitor μF
导线型 Lead Wire Type 外形图Dimensions①	带端子箱型 Terminal Box Type 外形图Dimensions②								
5IK60GU-AF	5IK60GU-AFT	60	1ph 100	50	1.00	320	470	1250	20
				60	1.10		380	1550	
5IK60GU-EF	5IK60GU-EFT	60	1ph 110	60	0.80	300	380	1550	12
			1ph 120		0.85				
5IK60GU-CF	5IK60GU-CFT	60	1ph 220	50	0.50	340	470	1250	4.0
			1ph 230		0.55				
5IK60GU-HF	5IK60GU-HFT	60	1ph 220	60	0.50	340	380	1550	4.0
			1ph 230		0.55				
5IK60GU-SF	5IK60GU-SFT	60	3ph 220	50	0.45	1000	470	1250	-
				60	0.40	800	380	1550	
5IK60GU-S3F	5IK60GU-S3FT	60	3ph 380	50	0.26	1000	470	1250	-
				60	0.23	800	380	1550	

- 各种安全规格以电动机铭牌上的型号名取得认证。
When the motor is approved under various safety standards, the model name on the nameplate is the approved model name.
- 注：“-A”型号中电压为110V时，配置电容器容量以实际铭牌为准。
Note:“-A” it means the voltage 110V, the assembly capacitor vaule it is according the labe.

装有减速器时的容许转矩 Gear Motor-Torque Table

- 减速器·中间减速器另售。● 电动机型号的□中为表示带端子箱型的记号(T)。
Gearhead and mid-gearbox can be sold separately. Enter the code that represents the terminal box type (T) in the box (□) within the model name.
- 减速器型号的□中为减速比的数值。□色表示与电动机同一方向运转，其他则为相反方向。
Enter the gear ratio in the box (□) within the model name.
The colored background □ indicates the same rotating direction of the motor while the rotating direction of others are opposite.
- 转速是以电动机的同步转速 (50Hz:1500r/min、60Hz:1800r/min) 为基准除以减速比而算出来的数值。实际转速将随负载大小变化而比所示数值减少2%~20%左右。
The speed is calculated by diving the motor's synchronous speed (50Hz:1500r/min、60Hz:1800r/min) by the gear ratio. The actual speed is 2%~20% less than the displayed value, depending on the size of the load.
- 希望以大于下表的减速比进行进一步减速时，可在电动机与减速器之间安装减速比为10的中间减速器。这时的容许转矩为20N·m。
To reduce the speed beyond the gear ratio in the table, attach a mid-gearbox (gear ratio:10) between the gearhead and motor. In that case, the permissible torque is 20N·m.

弧锥直角 SPIRAL BEVEL RIGHT ANGLE

容许力矩单位 Allowance Torque Unit: 上段 Upside (N.m) / 下段 Belowside (kgf.cm)

机型Type 电动机/减速器 Motor/Gearhead	减速比Gear Ratio	转速Speed r/min	7.5	9	12.5	15	18	25	30	36	50	60	75	90	100	120	150	180		
			50Hz	200	166	120	100	83	60	50	42	30	25	20	16	15	12	10	8	
		60Hz	240	200	144	120	100	72	60	50	36	30	24	20	18	15	12	10		
5IK60GU-AF□ 5IK60GU-EF□ 5IK60GU-CF□ 5IK60GU-HF□ 5IK60GU-SF□ 5IK60GU-S3F□	5GU□RC 5GU□RT	容许力矩 Allowance Torque	50Hz	2.37	2.84	3.95	4.73	5.68	7.89	9.47	10.2	14.2	17.0	20.0	20.0	20.0	20.0	20.0	20.0	20.0
			60Hz	1.91	2.29	3.18	3.82	4.58	6.36	7.64	8.25	11.5	13.7	17.2	20.0	20.0	20.0	20.0	20.0	20.0
		50Hz	24.2	29.0	40.3	48.3	58.0	80.5	96.6	104	145	174	200	200	200	200	200	200	200	200
		60Hz	19.48	23.37	32.46	38.96	46.75	64.93	77.92	84.1	117	140	175	200	200	200	200	200	200	200

电机尺寸图 Motor Size Chart

5IK60GU-AF□/5GU□RC 5IK60GU-EF□/5GU□RC	5IK60GU-CF□/5GU□RC 5IK60GU-HF□/5GU□RC	5IK60GU-SF□/5GU□RC 5IK60GU-S3F□/5GU□RC
------------------------------------------	------------------------------------------	-------------------------------------------

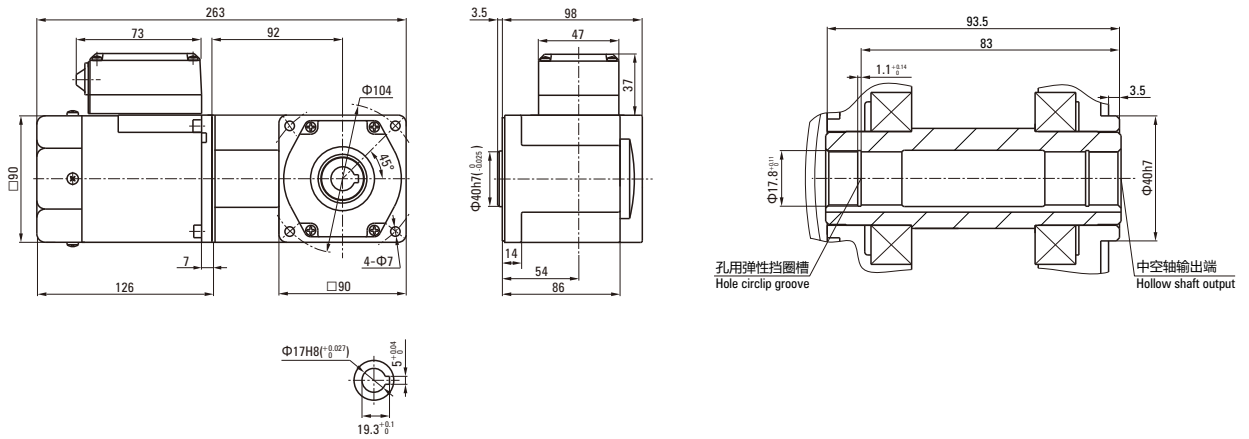

5IK60GU-AF□/5GU□RT 5IK60GU-EF□/5GU□RT	5IK60GU-CF□/5GU□RT 5IK60GU-HF□/5GU□RT	5IK60GU-SF□/5GU□RT 5IK60GU-S3F□/5GU□RT
------------------------------------------	------------------------------------------	-------------------------------------------

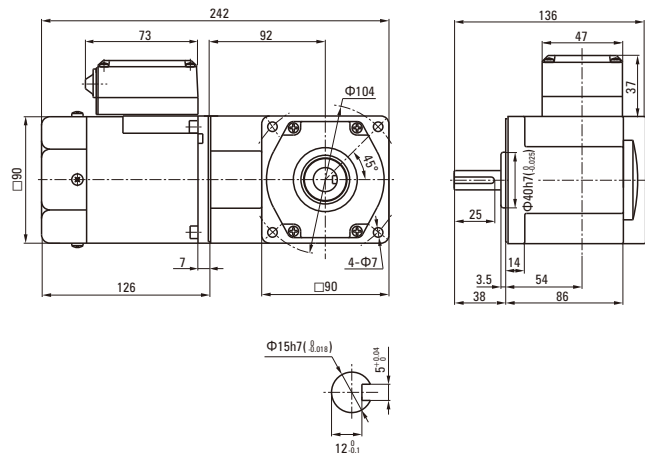

感应电动机 INDUCTION MOTORS

■ 90W □ 90mm



规格 Specs 连续额定 Continuous Rating

型号Model · 类型 Type 上段:齿轮轴 Upper:Pinion Shaft 下段()内:圆轴 Below:Round Shaft		输出功率 Output power W	电压 Voltage V	频率 Frequency Hz	电流 Current A	启动转矩 Starting Torque mN.m	额定转矩 Rated Torque mN.m	额定转速 Rated Speed r/min	电容器容量 Capacitor μF
导线型 Lead Wire Type 外形图Dimensions①	带端子箱型 Terminal Box Type 外形图Dimensions②								
5IK90GU-AF	5IK90GU-AFT	90	1ph 100	50	1.55	450	700	1250	25
				60	1.85		570	1550	
5IK90GU-EF	5IK90GU-EFT	90	1ph 110	60	1.40	500	570	1550	20
			1ph 120		1.45				
5IK90GU-CF	5IK90GU-CFT	90	1ph 220	50	0.72	450	700	1250	5.0
			1ph 230		0.70				
5IK90GU-HF	5IK90GU-HFT	90	1ph 220	60	0.71	450	570	1550	5.0
			1ph 230		0.75				
5IK90GU-SF	5IK90GU-SFT	90	3ph 220	50	0.60	1350	700	1250	-
				60	0.55	1100	570	1550	
5IK90GU-S3F	5IK90GU-S3FT	90	3ph 380	50	0.35	1350	700	1250	-
				60	0.32	1100	570	1550	

- 各种安全规格以电动机铭牌上的型号名取得认证。
When the motor is approved under various safety standards, the model name on the nameplate is the approved model name.
- 注：“-A”型号中电压为110V时，配置电容器容量以实际铭牌为准。
Note:“-A” it means the voltage 110V, the assembly capacitor vaule it is according the labe.

装有减速器时的容许转矩 Gear Motor-Torque Table

- 减速器-中间减速器另售。● 电动机型号的□中为表示带端子箱型的记号(T)。
Gearhead and mid-gearbox can be sold separately. Enter the code that represents the terminal box type (T) in the box (□) within the model name.
- 减速器型号的□中为减速比的数值。□色表示与电动机同一方向运转，其他则为相反方向。
Enter the gear ratio in the box (□) within the model name.
The colored background □ indicates the same rotating direction of the motor while the rotating direction of others are opposite.
- 转速是以电动机的同步转速 (50Hz:1500r/min、60Hz:1800r/min) 为基准除以减速比而算出来的数值。实际转速将随负载大小变化而比所示数值减少2%~20%左右。
The speed is calculated by diving the motor's synchronous speed (50Hz:1500r/min、60Hz:1800r/min) by the gear ratio. The actual speed is 2%~20% less than the displayed value, depending on the size of the load.
- 希望以大于下表的减速比进行进一步减速时，可在电动机与减速器之间安装减速比为10的中间减速器。这时的容许转矩为20N·m。
To reduce the speed beyond the gear ratio in the table, attach a mid-gearbox (gear ratio:10) between the gearhead and motor. In that case, the permissible torque is 20N·m.

弧锥直角 SPIRAL BEVEL RIGHT ANGLE

容许力矩单位 Allowance Torque Unit: 上段 Upside (N.m) / 下段 Belowside (kgf.cm)

机型Type		减速比Gear Ratio	7.5	9	12.5	15	18	25	30	36	50	60	75	90	100	120	150	180	
电动机/减速器 Motor/Gearhead	转速Speed r/min	50Hz	200	166	120	100	83	60	50	42	30	25	20	16	15	12	10	8	
		60Hz	240	200	144	120	100	72	60	50	36	30	24	20	18	15	12	10	
5IK90GU-AF□ 5IK90GU-EF□ 5IK90GU-CF□ 5IK90GU-HF□ 5IK90GU-SF□ 5IK90GU-S3F□	5GU□RC 5GU□RT	容许力矩 Allowance Torque	50Hz	3.55	4.26	5.92	7.10	8.52	11.8	14.2	15.3	20.0	20.0	20.0	20.0	20.0	20.0	20.0	20.0
			60Hz	2.86	3.44	4.77	5.73	6.87	9.54	11.5	12.4	17.2	20.0	20.0	20.0	20.0	20.0	20.0	20.0
			50Hz	29.2	35.1	48.7	58.4	70.1	97.4	117	126	175	200	200	200	200	200	200	200
			60Hz	29.2	35.1	48.7	58.4	70.1	97.4	117	126	175	200	200	200	200	200	200	200
			50Hz	29.2	35.1	48.7	58.4	70.1	97.4	117	126	175	200	200	200	200	200	200	200
			60Hz	29.2	35.1	48.7	58.4	70.1	97.4	117	126	175	200	200	200	200	200	200	200

电机尺寸图 Motor Size Chart

5IK90GU-AF□/5GU□RC 5IK90GU-CF□/5GU□RC 5IK90GU-SF□/5GU□RC
5IK90GU-EF□/5GU□RC 5IK90GU-HF□/5GU□RC 5IK90GU-S3F□/5GU□RC

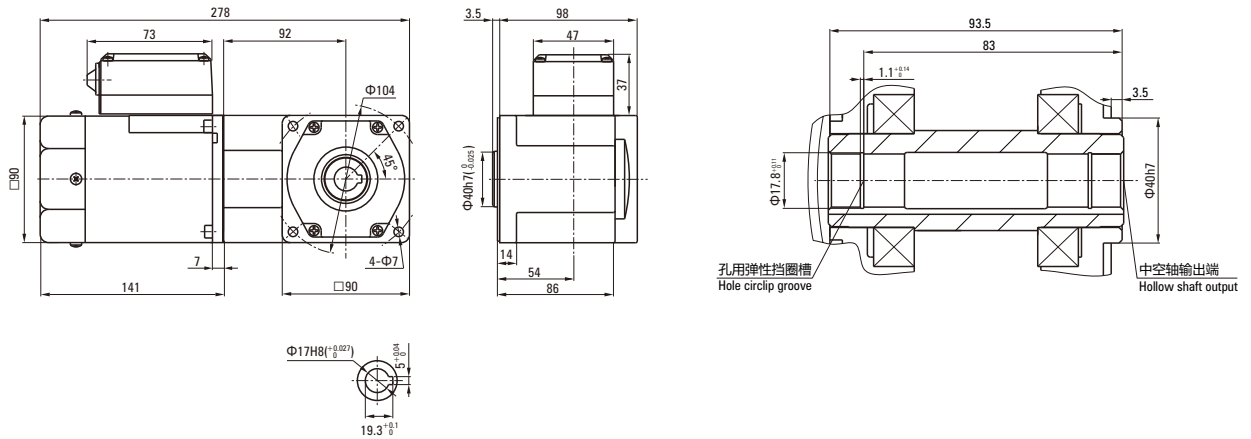

5IK90GU-AF□/5GU□RT 5IK90GU-CF□/5GU□RT 5IK90GU-SF□/5GU□RT
5IK90GU-EF□/5GU□RT 5IK90GU-HF□/5GU□RT 5IK90GU-S3F□/5GU□RT

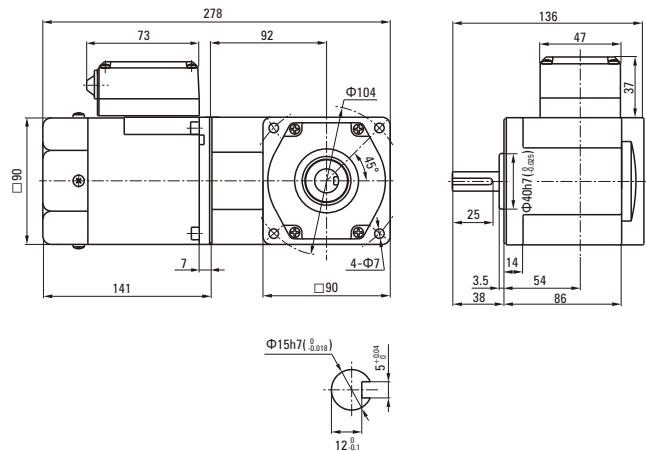

感应电动机 INDUCTION MOTORS

■ 120W □ 90mm



规格 Specs 连续额定 Continuous Rating

型号Model · 类型 Type 上段:齿轮轴 Upper:Pinion Shaft 下段()内:圆轴 Below:Round Shaft		输出功率 Output power W	电压 Voltage V	频率 Frequency Hz	电流 Current A	启动转矩 Starting Torque mN.m	额定转矩 Rated Torque mN.m	额定转速 Rated Speed r/min	电容器容量 Capacitor μF
导线型 Lead Wire Type 外形图Dimensions①	带端子箱型 Terminal Box Type 外形图Dimensions②								
5IK120GU-AF	5IK120GU-AFT	120	1ph 100	50	2.10	600	930	1250	30
				60	2.50		750	1550	
5IK120GU-EF	5IK120GU-EFT	120	1ph 110	60	1.65	600	750	1550	25
			1ph 120		1.80				
5IK120GU-CF	5IK120GU-CFT	120	1ph 220	50	1.00	650	930	1250	7.0
			1ph 230		0.95				
5IK120GU-HF	5IK120GU-HFT	120	1ph 220	60	1.00	600	750	1550	7.0
			1ph 230		0.95				
5IK120GU-SF	5IK120GU-SFT	120	3ph 220	50	0.70	1850	930	1250	-
				60	0.60		750	1550	
5IK120GU-S3F	5IK120GU-S3FT	120	3ph 380	50	0.40	1850	930	1250	-
				60	0.35		1600	750	

- 各种安全规格以电动机铭牌上的型号名取得认证。
When the motor is approved under various safety standards, the model name on the nameplate is the approved model name.
- 注：“-A”型号中电压为110V时，配置电容器容量以实际铭牌为准。
Note:“-A” it means the voltage 110V, the assembly capacitor vaule it is according the labe.

装有减速器时的容许转矩 Gear Motor-Torque Table

- 减速器·中间减速器另售。● 电动机型号的□中为表示带端子箱型的记号(T)。
Gearhead and mid-gearbox can be sold separately. Enter the code that represents the terminal box type (T) in the box (□) within the model name.
- 减速器型号的□中为减速比的数值。□色表示与电动机同一方向运转，其他则为相反方向。
Enter the gear ratio in the box (□) within the model name.
The colored background □ indicates the same rotating direction of the motor while the rotating direction of others are opposite.
- 转速是以电动机的同步转速 (50Hz:1500r/min、60Hz:1800r/min) 为基准除以减速比而算出来的数值。实际转速将随负载大小变化而比所示数值减少2%~20%左右。
The speed is calculated by diving the motor's synchronous speed (50Hz:1500r/min、60Hz:1800r/min) by the gear ratio. The actual speed is 2%~20% less than the displayed value, depending on the size of the load.
- 希望以大于下表的减速比进行进一步减速时，可在电动机与减速器之间安装减速比为10的中间减速器。这时的容许转矩为20N·m。
To reduce the speed beyond the gear ratio in the table, attach a mid-gearbox (gear ratio:10) between the gearhead and motor. In that case, the permissible torque is 20N·m.

弧锥直角 SPIRAL BEVEL RIGHT ANGLE

容许力矩单位 Allowance Torque Unit: 上段 Upside (N.m) / 下段 Belowside (kgf.cm)

机型Type 电动机/减速器 Motor/Gearhead	减速比Gear Ratio	转速Speed r/min	7.5	9	12.5	15	18	25	30	36	50	60	75	90	100	120	150	180		
			50Hz	200	166	120	100	83	60	50	42	30	25	20	16	15	12	10	8	
60Hz	240	200	144	120	100	72	60	50	36	30	24	20	18	15	12	10				
5IK120GU-AF□ 5IK120GU-EF□ 5IK120GU-CF□ 5IK120GU-HF□ 5IK120GU-SF□ 5IK120GU-S3F□	5GU□RC 5GU□RT	容许力矩 Allowance Torque	50Hz	4.73	5.68	7.89	9.47	11.4	15.8	18.9	20.0	20.0	20.0	20.0	20.0	20.0	20.0	20.0	20.0	20.0
			60Hz	3.82	4.58	6.36	7.64	9.16	12.7	15.3	16.5	20.0	20.0	20.0	20.0	20.0	20.0	20.0	20.0	20.0
		50Hz	48.3	58.0	80.5	96.6	116	161	193	200	200	200	200	200	200	200	200	200	200	200
		60Hz	39.0	46.7	64.9	77.9	93.5	130	156	168	200	200	200	200	200	200	200	200	200	200

电机尺寸图 Motor Size Chart

5IK120GU-AF□/5GU□RC 5IK120GU-CF□/5GU□RC 5IK120GU-SF□/5GU□RC
5IK120GU-EF□/5GU□RC 5IK120GU-HF□/5GU□RC 5IK120GU-S3F□/5GU□RC

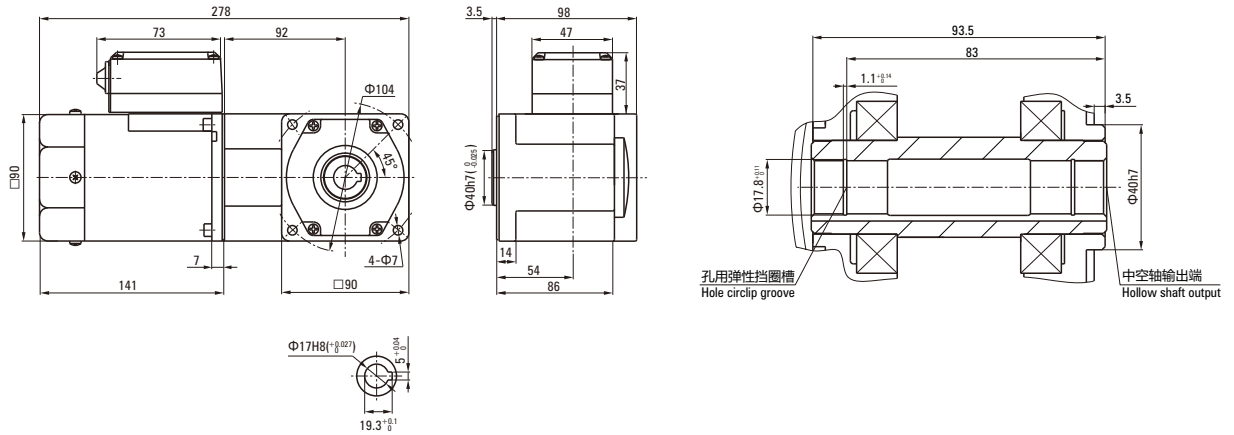

5IK120GU-AF□/5GU□RT 5IK120GU-CF□/5GU□RT 5IK120GU-SF□/5GU□RT
5IK120GU-EF□/5GU□RT 5IK120GU-HF□/5GU□RT 5IK120GU-S3F□/5GU□RT

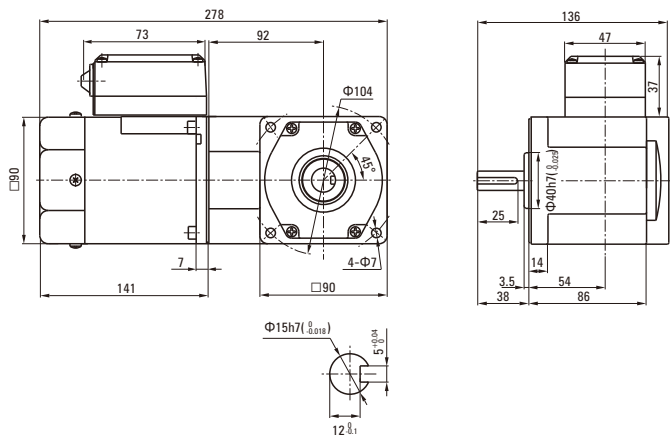

感应电动机 INDUCTION MOTORS

■ 120W □ 104mm

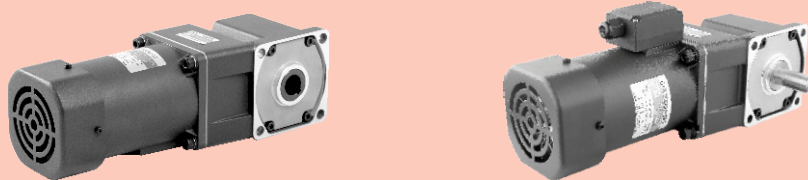

规格 Specs 连续额定 Continuous Rating

型号Model · 类型 Type 上段:齿轮轴 Upper:Pinion Shaft 下段()内:圆轴 Below:Round Shaft		输出功率 Output power W	电压 Voltage V	频率 Frequency Hz	电流 Current A	启动转矩 Starting Torque mN.m	额定转矩 Rated Torque mN.m	额定转速 Rated Speed r/min	电容器容量 Capacitor μF
导线型 Lead Wire Type 外形图Dimensions①	带端子箱型 Terminal Box Type 外形图Dimensions②								
6IK120GU-AF	6IK120GU-AFT	120	1ph 100	50	2.10	600	930	1250	30
				60	2.50		750	1550	
6IK120GU-EF	6IK120GU-EFT	120	1ph 110	60	1.70	600	750	1550	20
			1ph 120		1.80				
6IK120GU-CF	6IK120GU-CFT	120	1ph 220	50	0.95	750	930	1250	8.0
			1ph 230						
6IK120GU-HF	6IK120GU-HFT	120	1ph 220	60	0.95	700	750	1550	8.0
			1ph 230		1.00				
6IK120GU-SF	6IK120GU-SFT	120	3ph 220	50	0.75	2200	890	1300	-
				60	0.70	2000	730	1600	
6IK120GU-S3F	6IK120GU-S3FT	120	3ph 380	50	0.43	2200	890	1300	-
				60	0.40	2000	730	1600	

- 各种安全规格以电动机铭牌上的型号名取得认证。
When the motor is approved under various safety standards, the model name on the nameplate is the approved model name.
- 注：“-A”型号中电压为110V时，配置电容器容量以实际铭牌为准。
Note:“-A” it means the voltage 110V, the assembly capacitor vaule it is according the labe.

装有减速器时的容许转矩 Gear Motor-Torque Table

- 减速器-中间减速器另售。● 电动机型号的□中为表示带端子箱型的记号(T)。
Gearhead and mid-gearbox can be sold separately. Enter the code that represents the terminal box type (T) in the box (□) within the model name.
- 减速器型号的□中为减速比的数值。□色表示与电动机同一方向运转，其他则为相反方向。
Enter the gear ratio in the box (□) within the model name.
The colored background □ indicates the same rotating direction of the motor while the rotating direction of others are opposite.
- 转速是以电动机的同步转速 (50Hz:1500r/min、60Hz:1800r/min) 为基准除以减速比而算出来的数值。实际转速将随负载大小变化而比所示数值减少2%~20%左右。
The speed is calculated by diving the motor's synchronous speed (50Hz:1500r/min、60Hz:1800r/min) by the gear ratio. The actual speed is 2%~20% less than the displayed value, depending on the size of the load.
- 希望以大于下表的减速比进行进一步减速时，可在电动机与减速器之间安装减速比为10的中间减速器。这时的容许转矩为60N·m。
To reduce the speed beyond the gear ratio in the table, attach a mid-gearbox (gear ratio:10) between the gearhead and motor. In that case, the permissible torque is 60N·m.

弧锥直角 SPIRAL BEVEL RIGHT ANGLE

容许力矩单位 Allowance Torque Unit: 上段 Upside (N.m) / 下段 Belowside (kgf.cm)

机型Type 电动机/减速器 Motor/Gearhead	减速比Gear Ratio	转速Speed r/min	7.5	9	12.5	15	18	25	30	36	50	60	75	90	100	120	150	180	
			50Hz	200	166	120	100	83	60	50	42	30	25	20	16	15	12	10	8
60Hz	240	200	144	120	100	72	60	50	36	30	24	20	18	15	12	10			
6IK120GU-AF□ 6IK120GU-EF□ 6IK120GU-CF□ 6IK120GU-HF□ 6IK120GU-SF□ 6IK120GU-S3F□	6GU□RC 6GU□RT	容许力矩 Allowance Torque	50Hz	4.26	5.68	7.89	9.47	11.4	15.8	18.9	22.7	28.4	34.1	42.6	51.1	56.8	60.0	60.0	60.0
			60Hz	3.44	4.58	6.36	7.64	9.16	12.7	15.3	18.3	22.9	27.5	34.4	41.2	45.8	55.0	60.0	60.0
		50Hz	43.5	58.0	80.5	96.6	116	161	193	232	290	348	435	522	580	600	600	600	600
		60Hz	35.1	46.7	64.9	77.9	93.5	130	156	187	234	280	351	421	467	561	600	600	600

电机尺寸图 Motor Size Chart

6IK120GU-AF□/6GU□RC 6IK120GU-CF□/6GU□RC 6IK120GU-SF□/6GU□RC
6IK120GU-EF□/6GU□RC 6IK120GU-HF□/6GU□RC 6IK120GU-S3F□/6GU□RC

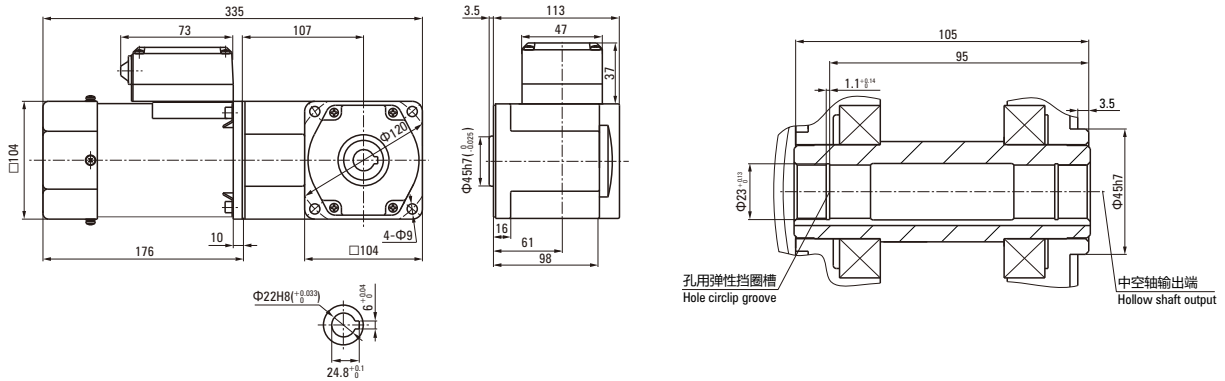

6IK120GU-AF□/6GU□RT 6IK120GU-CF□/6GU□RT 5IK120GU-SF□/6GU□RT
6IK120GU-EF□/6GU□RT 6IK120GU-HF□/6GU□RT 5IK120GU-S3F□/6GU□RT

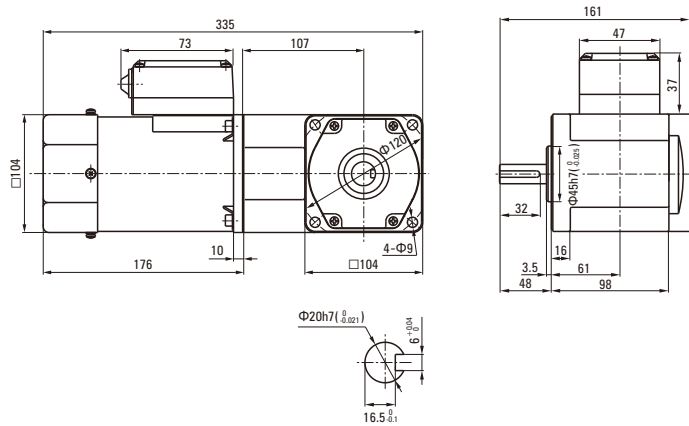

感应电动机 INDUCTION MOTORS

■ 140W □ 104mm



规格 Specs 连续额定 Continuous Rating

型号Model · 类型 Type 上段:齿轮轴 Upper:Pinion Shaft 下段()内:圆轴 Below:Round Shaft		输出功率 Output power W	电压 Voltage V	频率 Frequency Hz	电流 Current A	启动转矩 Starting Torque mN.m	额定转矩 Rated Torque mN.m	额定转速 Rated Speed r/min	电容器容量 Capacitor μF
导线型 Lead Wire Type 外形图Dimensions①	带端子箱型 Terminal Box Type 外形图Dimensions②								
6IK140GU-AF	6IK140GU-AFT	140	1ph 100	50	2.70	700	1080	1250	35
				60	3.00		870	1550	
6IK140GU-EF	6IK140GU-EFT	140	1ph 110	60	1.80	700	850	1600	25
			1ph 120		1.95				
6IK140GU-CF	6IK140GU-CFT	140	1ph 220	50	1.05	850	1040	1350	10
			1ph 230		1.15				
6IK140GU-HF	6IK140GU-HFT	140	1ph 220	60	1.05	750	850	1600	10
			1ph 230		1.15				
6IK140GU-SF	6IK140GU-SFT	140	3ph 220	50	0.85	2700	1080	1250	-
				60	0.75	2200	870	1550	
6IK140GU-S3F	6IK140GU-S3FT	140	3ph 380	50	0.49	2700	1080	1250	-
				60	0.43	2200	870	1550	

- 各种安全规格以电动机铭牌上的型号名取得认证。
When the motor is approved under various safety standards, the model name on the nameplate is the approved model name.
- 注：“-A”型号中电压为110V时，配置电容器容量以实际铭牌为准。
Note:“-A” it means the voltage 110V, the assembly capacitor vaule it is according to the labe.

装有减速器时的容许转矩 Gear Motor-Torque Table

- 减速器-中间减速器另售。● 电动机型号的□中为表示带端子箱型的记号(T)。
Gearhead and mid-gearbox can be sold separately. Enter the code that represents the terminal box type (T) in the box (□) within the model name.
- 减速器型号的□中为减速比的数值。□色表示与电动机同一方向运转，其他则为相反方向。
Enter the gear ratio in the box (□) within the model name.
The colored background □ indicates the same rotating direction of the motor while the rotating direction of others are opposite.
- 转速是以电动机的同步转速 (50Hz:1500r/min、60Hz:1800r/min) 为基准除以减速比而算出来的数值。实际转速将随负载大小变化而比所示数值减少2%~20%左右。
The speed is calculated by diving the motor's synchronous speed (50Hz:1500r/min、60Hz:1800r/min) by the gear ratio. The actual speed is 2%~20% less than the displayed value, depending on the size of the load.
- 希望以大于下表的减速比进行进一步减速时，可在电动机与减速器之间安装减速比为10的中间减速器。这时的容许转矩为60N·m。
To reduce the speed beyond the gear ratio in the table, attach a mid-gearbox (gear ratio:10) between the gearhead and motor. In that case, the permissible torque is 60N·m.

弧锥直角 SPIRAL BEVEL RIGHT ANGLE

容许力矩单位 Allowance Torque Unit: 上段 Upside (N.m) / 下段 Belowside (kgf.cm)

机型Type 电动机/减速器 Motor/Gearhead	减速比Gear Ratio	转速Speed r/min	7.5	9	12.5	15	18	25	30	36	50	60	75	90	100	120	150	180		
			50Hz	200	166	120	100	83	60	50	42	30	25	20	16	15	12	10	8	
60Hz	240	200	144	120	100	72	60	50	36	30	24	20	18	15	12	10				
6IK140GU-AF□ 6IK140GU-EF□ 6IK140GU-CF□ 6IK140GU-HF□ 6IK140GU-SF□ 6IK140GU-S3F□ 6GU□RC 6GU□RT	容许力矩 Allowance Torque	50Hz	4.97	6.63	9.21	11.0	13.3	18.4	22.1	26.5	33.1	39.8	49.7	59.6	60.0	60.0	60.0	60.0	60.0	
			60Hz	4.01	5.34	7.42	8.91	10.7	14.8	17.8	21.4	26.7	32.1	40.1	48.1	53.4	60.0	60.0	60.0	60.0
		60Hz	40.9	54.5	75.8	90.9	109	152	182	218	273	327	409	491	545	600	600	600	600	600

电机尺寸图 Motor Size Chart

6IK140GU-AF□/6GU□RC 6IK140GU-CF□/6GU□RC 5IK140GU-SF□/6GU□RC
6IK140GU-EF□/6GU□RC 6IK140GU-HF□/6GU□RC 5IK140GU-S3F□/6GU□RC

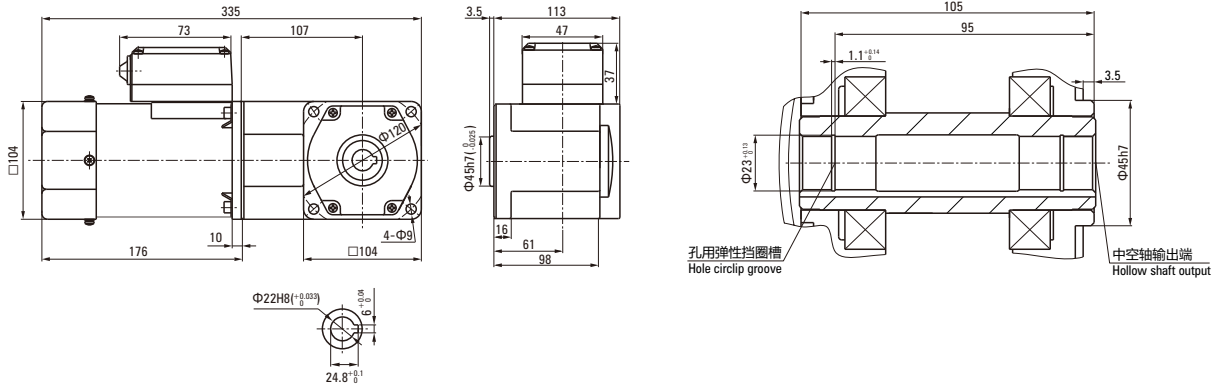

6IK140GU-AF□/6GU□RT 6IK140GU-CF□/6GU□RT 5IK140GU-SF□/6GU□RT
6IK140GU-EF□/6GU□RT 6IK140GU-HF□/6GU□RT 5IK140GU-S3F□/6GU□RT

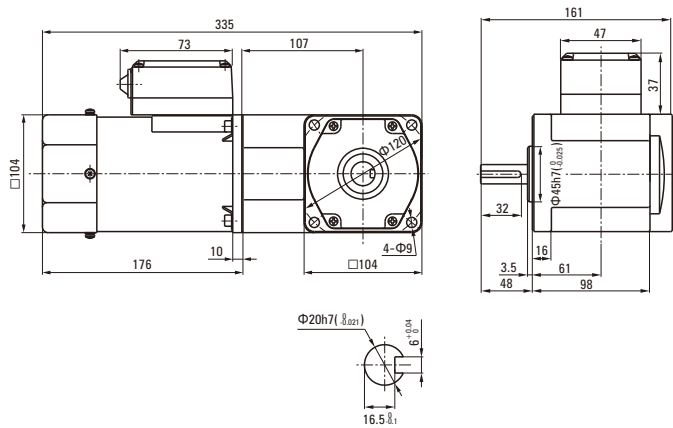

感应电动机 INDUCTION MOTORS

■ 200W □ 104mm

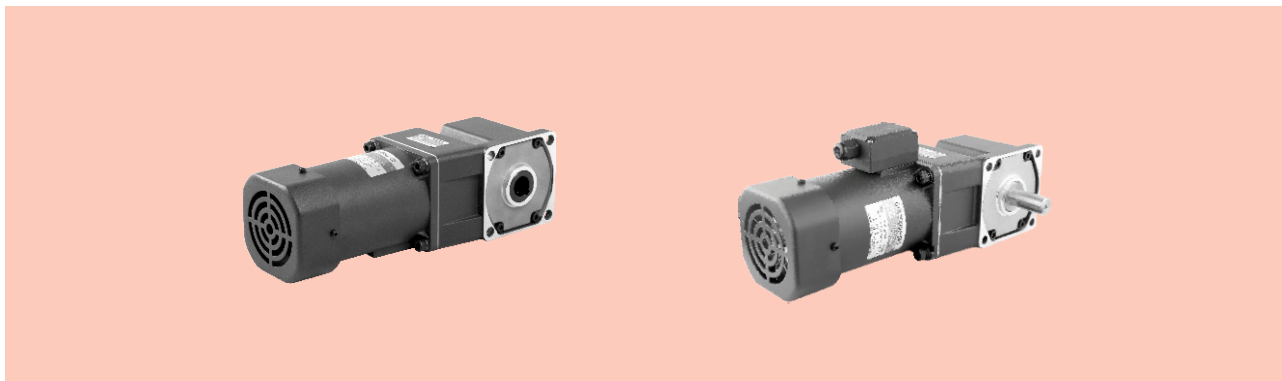

规格 Specs 连续额定 Continuous Rating

型号Model · 类型 Type 上段:齿轮轴 Upper:Pinion Shaft 下段()内:圆轴 Below:Round Shaft		输出功率 Output power W	电压 Voltage V	频率 Frequency Hz	电流 Current A	启动转矩 Starting Torque mN.m	额定转矩 Rated Torque mN.m	额定转速 Rated Speed r/min	电容器容量 Capacitor μF
导线型 Lead Wire Type 外形图Dimensions①	带端子箱型 Terminal Box Type 外形图Dimensions②								
6IK200GU-AF	6IK200GU-AFT	200	1ph 100	50	3.20	900	1520	1250	45
				60	3.50		1230	1550	
6IK200GU-EF	6IK200GU-EFT	200	1ph 110	60	2.75	850	1230	1550	35
			1ph 120		2.65				
6IK200GU-CF	6IK200GU-CFT	200	1ph 220	50	1.40	1000	1520	1250	10
			1ph 230						
6IK200GU-HF	6IK200GU-HFT	200	1ph 220	60	1.40	900	1230	1550	10
			1ph 230						
6IK200GU-SF	6IK200GU-SFT	200	3ph 220	50	1.20	3400	1520	1250	-
				60	1.00		1230	1550	
6IK200GU-S3F	6IK200GU-S3FT	200	3ph 380	50	0.69	3400	1520	1250	-
				60	0.58		1230	1550	

- 各种安全规格以电动机铭牌上的型号名取得认证。
When the motor is approved under various safety standards, the model name on the nameplate is the approved model name.
- 注：“-A”型号中电压为110V时，配置电容器容量以实际铭牌为准。
Note:“-A” it means the voltage 110V, the assembly capacitor vaule it is according the labe.

装有减速器时的容许转矩 Gear Motor-Torque Table

- 减速器-中间减速器另售。● 电动机型号的□中为表示带端子箱型的记号(T)。
Gearhead and mid-gearbox can be sold separately. Enter the code that represents the terminal box type (T) in the box (□) within the model name.
- 减速器型号的□中为减速比的数值。□色表示与电动机同一方向运转，其他则为相反方向。
Enter the gear ratio in the box (□) within the model name.
The colored background □ indicates the same rotating direction of the motor while the rotating direction of others are opposite.
- 转速是以电动机的同步转速 (50Hz:1500r/min、60Hz:1800r/min) 为基准除以减速比而算出来的数值。实际转速将随负载大小变化而比所示数值减少2%~20%左右。
The speed is calculated by diving the motor's synchronous speed (50Hz:1500r/min、60Hz:1800r/min) by the gear ratio. The actual speed is 2%~20% less than the displayed value, depending on the size of the load.
- 希望以大于下表的减速比进行进一步减速时，可在电动机与减速器之间安装减速比为10的中间减速器。这时的容许转矩为60N·m。
To reduce the speed beyond the gear ratio in the table, attach a mid-gearbox (gear ratio:10) between the gearhead and motor. In that case, the permissible torque is 60N·m.

弧锥直角 SPIRAL BEVEL RIGHT ANGLE

容许力矩单位 Allowance Torque Unit: 上段 Upside (N.m) / 下段 Belowside (kgf.cm)

机型Type 电动机/减速器 Motor/Gearhead	减速比Gear Ratio	转速Speed r/min	7.5	9	12.5	15	18	25	30	36	50	60	75	90	100	120	150	180		
			50Hz	200	166	120	100	83	60	50	42	30	25	20	16	15	12	10	8	
60Hz	240	200	144	120	100	72	60	50	36	30	24	20	18	15	12	10				
6IK200GU-AF□ 6IK200GU-EF□ 6IK200GU-CF□ 6IK200GU-HF□ 6IK200GU-SF□ 6IK200GU-S3F□	6GU□RC 6GU□RT	容许力矩 Allowance Torque	50Hz	9.28	11.1	13.9	16.7	20.1	25.2	30.3	36.3	50.4	60.0	60.0	60.0	60.0	60.0	60.0	60.0	60.0
			60Hz	7.49	8.98	11.2	13.5	16.2	20.3	24.4	29.3	40.7	48.8	60.0	60.0	60.0	60.0	60.0	60.0	60.0
		50Hz	94.7	114	142	171	205	257	30.9	370	515	600	600	600	600	600	600	600	600	600
		60Hz	76.4	91.7	115	138	165	207	249	299	415	498	600	600	600	600	600	600	600	600

电机尺寸图 Motor Size Chart

6IK200GU-AF□/6GU□RC 6IK200GU-CF/6GU□RC 6IK200GU-SF□/6GU□RC
6IK200GU-EF□/6GU□RC 6IK200GU-HF/6GU□RC 6IK200GU-S3F□/6GU□RC

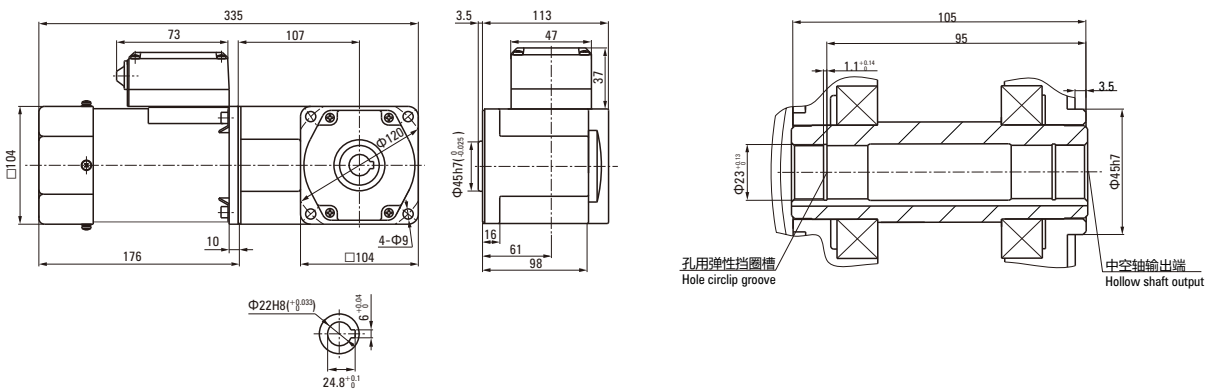

6IK200GU-AF□/6GU□RT 6IK200GU-CF/6GU□RT 6IK200GU-SF□/6GU□RT
6IK200GU-EF□/6GU□RT 6IK200GU-HF/6GU□RT 6IK200GU-S3F□/6GU□RT

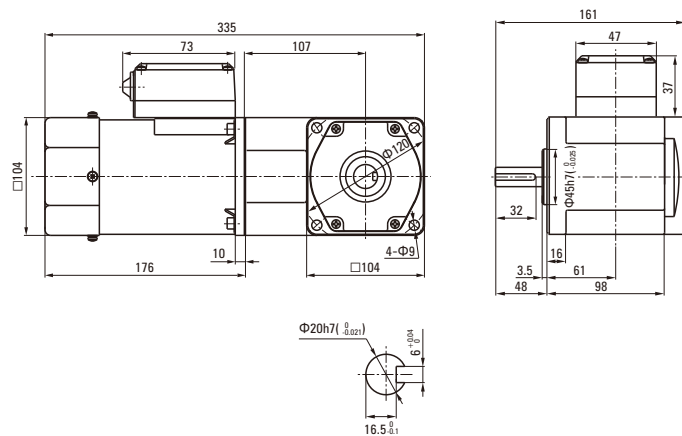

连接图 Wiring Diagram

● 运转方向指从电动机轴看来的方向。CW表示顺时针方向，CCW表示逆时针方向。

The direction of motor rotation is as viewed from the shaft end of motor. CW represents the clockwise direction, while CCW represents the counterclockwise direction.

● 表中所记品名为齿轮轴型，圆轴型亦同。

Name indicated in the list is pinion shaft type, also valid for the equivalent round shaft type.

导线型 Lead Wire Type		
6IK200GU-AF、6IK200GU-EF、6IK200GU-HF、6IK200GU-CF		6IK200GU-SF(S3F)
<p>顺时针方向CW</p> <p>电容器 Capacitance</p>	<p>逆时针方向CCW</p> <p>电容器 Capacitance</p>	<p>顺时针方向CW</p> <p>逆时针方向CCW 若对换R、S、T中任意二条，电动机作逆时针方向运转 To change the rotation direction change any two connections among R, S and T</p>
带端子箱型 Terminal Box Type		
6IK200GU-AFT、6IK200GU-EFT、6IK200GU-HFT、6IK200GU-CFT		6IK200GU-SFT(3FT)
<p>顺时针方向CW</p> <p>电容器 Capacitance</p>	<p>逆时针方向CCW</p> <p>电容器 Capacitance</p>	<p>顺时针方向CW</p> <p>逆时针方向CCW 若对换U、V、W中任意二条，电动机作逆时针方向运转 To change the rotation direction change any two connections among U, V and W</p>

请注意 Note:

单相电动机运转方向的转换应在电动机停止后进行。

Change the direction of single-phase motor rotation only after bring the motor to a stop.

若在电动机运转时转换运转方向，可能发生无法转换运转方向或须费时较久的情况。

If an attempt is made to change the direction of rotation while the motor is rotating, motor may ignore reversing command or change its direction of rotation after some delay.